

FLOWMETER

ENGINEERING MANUAL

1800 SERIES



FLOW MEASUREMENT & CONTROL SOLUTIONS

PRODUCT OVERVIEW

ISTEC's "Super-Jet" 1800 Series are industrial grade water meters available in ½" through 12" sizes. All sizes incorporate a variety of standard features such as U.S. gallon register, hermetically sealed non-resettable counter, trickle flow indicator and pulse output. ISTEC "Super-Jet" design leaves only the turbine immersed, resulting in reliable and long lasting performance.

For easy installation, all ISTEC flow meters up to 1½" are available with union connections; 2" and larger sizes are designed with standard flanges. The smooth running turbine, together with a self-aligning suspension bearing system and other innovative features provides superior reliability and accuracy that meets or exceeds AWWA standards.

In addition, a high temperature version (350°F) of the 2", 3" and 4" meters is available.

COMPONENT DESCRIPTION

BODY

Pipe Size ½" (15mm) To 1½" (40mm)	Brass
Pipes Size 2" (50mm) To 12" (300mm)	Cast Iron

FLOW INSERT

Turbine	Fiberglass
Turbine Axle	Chrome/Nickel/Steel
Bearing Material	Stainless Steel/Sapphire
Magnetic Transfer	Cobalt/Samarium
Gears, Axles, Screws	Stainless Steel

COUNTER

Calibration	U.S. Gallons (Metric Available)
Housing	Plastic, Hermetically Sealed
Gears	Plastic
Axles	Chrome/Nickel/Steel

ENVIRONMENTAL

Maximum Temperature	248°F (120°C)
Maximum Pressure	232 PSI (16 BAR)

TECHNICAL SPECIFICATIONS

P/N		1800	1805	1810	1811/12	1815	1816	1820	
F L O W	R A N G E	MIN	0.13 gpm	0.22 gpm	0.4 gpm	0.4 gpm	0.7 gpm	0.7 gpm	0.88 gpm
			30 lph	50 lph	90 lph	90 lph	160 lph	160 lph	200 lph
	CONT	6.6 gpm	11 gpm	26.32 gpm	26.32 gpm	43.86 gpm	43.86 gpm	65.8 gpm	
		1.5 m ³ ph	2.5 m ³ ph	6 m ³ ph	6 m ³ ph	10 m ³ ph	10 m ³ ph	15 m ³ ph	
	MAX	13.2 gpm	22 gpm	52.6 gpm	52.6 gpm	87.22 gpm	87.22 gpm	131.6 gpm	
3 m ³ ph		5 m ³ ph	12 m ³ ph	12 m ³ ph	20 m ³ ph	20 m ³ ph	30 m ³ ph		
PULSE	gal/pulse	1	1	1	1	1	1	10	
	liters/pulse	1	1	1	1	1	1	10	
WEIGHT	pounds	2.3	2.5	6.4	6.8	11.3	12.1	27.5	
	kilograms	1	1.1	2.9	3.1	5.1	5.5	12.5	
P/N		1825	1830	1835	1840	1845	1850	1855	
F L O W	R A N G E	MIN	2.64 gpm	14.09 gpm	5.26 gpm	26.32 gpm	43.86 gpm	53 gpm	66 gpm
			0.6 m ³ ph	3.2 m ³ ph	1.2 m ³ ph	6 m ³ ph	10 m ³ ph	12 m ³ ph	15 m ³ ph
	CONT	66.04 gpm	140.89 gpm	263.2 gpm	657.9 gpm	1096.5 gpm	1761 gpm	2642 gpm	
		15 m ³ ph	32 m ³ ph	60 m ³ ph	150 m ³ ph	250 m ³ ph	400 m ³ ph	600 m ³ ph	
	MAX	264.2 gpm	396.26 gpm	790 gpm	1535 gpm	2631 gpm	4400 gpm	5284 gpm	
60 m ³ ph		90 m ³ ph	180 m ³ ph	350 m ³ ph	600 m ³ ph	1000 m ³ ph	1200 m ³ ph		
PULSE	gal/pulse	10	10	10	100	100	100	100	
	liters/pulse	10	10	10	100	100	100	100	
WEIGHT	pounds	24.4	27.5	43.7	71.6	99.2	260.0	300.0	
	kilograms	11.1	12.5	19.8	32.5	45	118	136	

TYPICAL FLOWMETER ACCURACY CHART

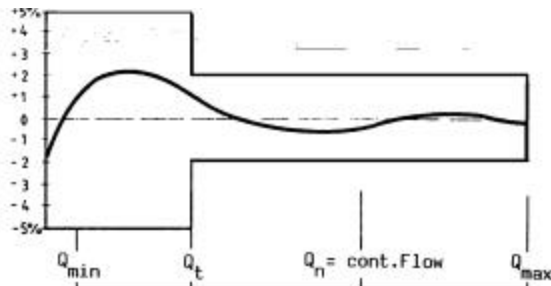

DIMENSIONS

P/N	1800	1805	1810	1811/12	181	1816	1820
Size	½"(H) 15mm	¾"(A) 20mm	1" (H) 25mm	1" (D) 25mm	1½"(H) 40mm	1½"(D) 40mm	2"(H) 50mm
h	¾" 20mm	¾" 20mm	1-¾" 45mm	1-¼" 31mm	2" 50mm	7/8" 21mm	3-¼" 83mm
H	3-¾" 95mm	3-¾" 95mm	5-½" 140mm	7-½" 191mm	6-¼" 155mm	8-¾" 221mm	7-⅛" 180mm
L	4-½" 114mm	5" 127mm	10-¼" 260mm	5-7/8" 150mm	11-7/8" 300mm	7-7/8" 200mm	10-½" 270mm
P/N	1825	1830	1835	1840	1845	1850	1855
Size	2"(A) 50mm	3"(A) 80mm	4"(A) 100mm	6"(A) 150mm	8"(A) 200mm	10"(A) 250mm	12"(A) 300mm
h	3" 75mm	3-¾" 94mm	4-3/8" 110mm	5-3/4" 145mm	6-3/4" 172mm	8" 203mm	9-½" 241mm
H	5-½" 141mm	5-½" 141mm	7-7/8" 200mm	8-½" 217mm	8-½" 217mm	9-¼" 240mm	10-¼" 260mm
L	7-7/8" 200mm	8-7/8" 225mm	9-7/8" 250mm	11-7/8" 300mm	13-3/4" 350mm	17-3/4" 450mm	19-3/4" 502mm

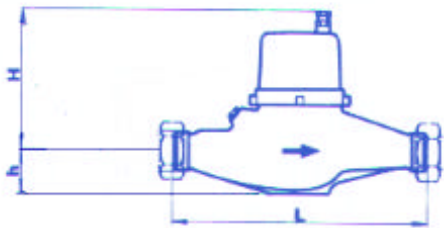

Flowmeter ½" to 1-1/2"

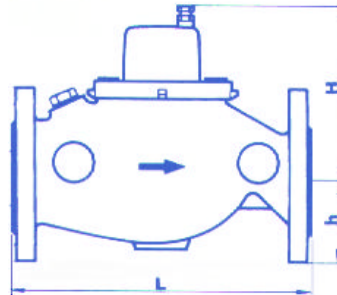

Flowmeter 2" to 12"

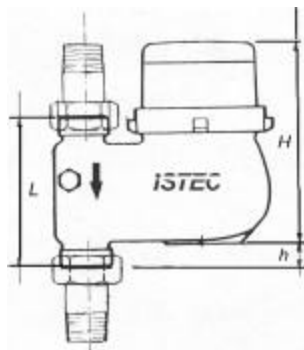

Flowmeter 1" & 1-1/2" Downflow / Upflow

FLOWMETER SPECIFICATION: 1800 SERIES

AS MANUFACTURED BY ISTECH CORPORATION

5 Park Lake Road, Sparta, NJ 07871

The contractor shall furnish and install as shown on the plans a multi-wing turbine type Flowmeter. The Flowmeter shall be factory assembled, calibrated and tested, incorporating the following features:

BODY

The Flowmeter shall have a line size of _____ inch(s)/_____ mm(s). The body shall be constructed of brass (from ½” (15mm) to 1-1/2” (40mm) sizes) or cast iron (from 2” (50mm) to 12” (300mm)).

FLOW INSERT

The Flow Insert shall be the “single-jet” type on the ½” (15mm) and ¾” (20mm) sizes. It shall be the “multi-jet” style on the 1” (25mm) through 12” (300mm) sizes. The insert assembly shall be capable of being replaced without removing the meter body.

COUNTER

The unit shall have a hermetically sealed “dry-type” mechanical counter. The counter will read in U.S. gallons (cubic meters available) and shall be non-resettable.

ACCURACY

The Flowmeter shall have an accuracy of $\pm 1.5\%$.

FLOW RANGE

The Flowmeter shall have a minimum flow rating of _____ gpm (_____ lph/or m^3 ph). It shall have a continuous flow rating of _____ gpm (_____ m^3 ph). The peak flow, which the meter can not be subjected to for more than one hour per day, shall be _____ gpm (_____ m^3 ph).

PULSER

The Flowmeter shall provide a “pulse” type output of 1 contact closure for every 1/10/100 gallon(s) of flow (metric counters provide 1 pulse for every 1/10/100 liters of flow).